



Request for Proposal – Number 387

for

Pedestrian and Bike Bridges

on the

Wildlife and Conservation Corridor

Jekyll Island, Georgia

Date Issued:

June 16, 2026

Deadline to Submit Proposals:

Friday, July 27, 2026

3:00 P.M. Eastern

Section 1

General Background and Project Information

1.1 Overview.

This Request for Proposal (“RFP”) is an invitation by the Jekyll Island State Park Authority, a public corporation and instrumentality of the State of Georgia, (the “JIA”) to qualified and experienced contractors to submit proposals for the construction of Four (4) pedestrian and bike bridges (the, “Project”) located within Jekyll Island’s new wildlife conservation corridor (the “Property”).

Information on the requested Project concept and the Property is provided in the Exhibits attached to this RFP, and which are incorporated herein for all purposes.

The goal of this RFP is to select a partner who will further the development of Jekyll Island’s newest conservation project. This Project offers the successful respondent a unique opportunity to leave a lasting impression on a true Jekyll Island treasure.

JIA will review and evaluate all responsive proposals submitted in a timely manner in accordance with this RFP, and, following evaluation, JIA personnel will make a preliminary recommendation to the JIA Board of Directors (the “Board”) for consideration and approval. Subject to and following Board approval, JIA personnel and the successful respondent will enter into a contract for the Project (the “Contract”) on JIA’s standard terms. The successful respondent will be required to coordinate construction and operational plans with JIA, including, JIA’s conservation department and other personnel to ensure the Project minimizes impact to the natural environment and is built to specification.

1.2 Background on Jekyll Island and the JIA.

- (a) Jekyll Island. Jekyll Island is a unique, state-owned barrier island that balances conserving and preserving natural, historic, and cultural resources with providing accessible, affordable recreation, vacation, and educational opportunities for the people of Georgia and beyond. Surrounded by picturesque marshes and breathtaking oceanfront, Jekyll Island is a peaceful coastal habitat. The barrier island contains one of the few remaining intact maritime forests on the Eastern seaboard. Originally inhabited by Native Americans, Jekyll Island was explored by the French and Spanish and first settled by the English. From early settlers to America’s social elite to today’s explorers, this special barrier island has captured imaginations for generations. Now a top ranked tourist destination, Jekyll Island hosts more than 3.5 million visitors annually.
- (b) Jekyll Island Authority. Recognizing that the natural beauty and vibrant history of Jekyll Island set it apart from any other coastal destination, the Governor and the Georgia General Assembly established Jekyll Island as a state park in 1947, entrusting its care and preservation to the Jekyll Island State Park Authority (often referred to simply as the “Jekyll Island Authority”) in 1950 through an act of the Georgia General Assembly. Since its inception, JIA has conserved Jekyll Island’s natural and historic resources, while ensuring it remains an inviting destination for residents and guests. Today, JIA is a self-supporting state entity responsible for the management and stewardship of Jekyll Island.
- (c) Wildlife Conservation Corridor. In 2022, the JIA approved a Golf Improvement Master Plan. Part of that plan included decommissioning 9 holes of the former Oleander course and creating a wildlife conservation corridor. Creation of the corridor has given JIA the unique opportunity to restore approximately 50 acres of land within the interior mid-island area of Jekyll Island. Once complete the wildlife conservation corridor will include a

network of trails and points of interest for visitors to explore. Part of that network will include the four bridge crossings which are the subject of this RFP.

1.3 Property Information. The Property and site for the Project are more particularly shown on Exhibit “B” attached hereto and incorporated herein for all purposes.

1.4 Jekyll Island Contract Structure. Upon award of the Project by the Board, JIA will enter into a contract for the services contemplated herein this RFP with the successful respondent on terms mutually agreeable to both parties and in accordance with this RFP and the successful proposal. All respondents should take note that JIA, as a public corporation and instrumentality of the State of Georgia, is bound by certain provisions of Georgia law regarding contracting with a state entity, including but not limited to, provisions regarding indemnity, liability, and insurance requirements. As part of the contracting process, JIA may require the following:

- (a) **Guaranty.** JIA may require one or more principals of the successful Respondent, or third parties of sufficient means and creditworthiness, to guarantee the full, faithful, and prompt performance of all obligations under the Contract. Respondent should consider this contingency in its proposal.
- (b) **Background Checks and References.** JIA may conduct a background and reference check, including a credit check, on the successful Respondent and any principals or key employees with significant managerial or operational roles, prior to executing the Contract. Respondents should be prepared to provide authorization for background checks, character references, and financial references (e.g., from institutional lenders) upon request.
- (c) **Business Authorizations.** The successful Respondent must meet all legal requirements to do business in and contract with the State of Georgia prior to JIA executing the Contract, including, without limitation, participation in verification of lawful presence verification (i.e., E-Verify), workers’ compensation insurance programs, Drug-Free Workplace requirements, and other requirements for contracting with state entities. The successful Respondent must be able to obtain all required permits or licenses, if any, to satisfactorily discharge its obligations under the Contract.

1.5 Studies and Reference Materials. The following documents may aid the Respondent in preparing a responsive proposal:

- (a) 2021 Jekyll Island Master Plan: <https://www.jekyllisland.com/authority/documents/master-plan/>
- (b) 2022 Golf Improvement Plan: <https://www.jekyllisland.com/authority/documents/golf-improvement-plan/>
- (c) 2018 Jekyll Island Carrying Capacity & Infrastructure Assessment: <https://www.jekyllisland.com/authority/documents/jekyll-island-carrying-capacity-infrastructure-assessment/>
- (d) 2020 Jekyll Island Conservation Plan: <https://www.jekyllisland.com/authority/documents/jekyll-island-conservation-plan/>
- (e) 2025 Oleander Golf Course Restoration Plan: <https://www.jekyllisland.com/authority/documents/oleander-golf-course-restoration-plan/>
- (f) Other Helpful Documents: <https://www.jekyllisland.com/authority/documents/>

Section 2
Process

2.1 Tentative Schedule of Events. This schedule of events represents JIA’s best estimate of the schedule that will be followed. Delays may occur that may necessitate adjustments to the proposed schedule, and if a component of this schedule is delayed, JIA may adjust the remainder of the schedule appropriately. JIA will give notice via email to prospective respondents (each a “Respondent”) who have requested notice via email of any such adjustment and post the same to the JIA website at <https://www.jekyllisland.com/authority/rfps/> (the “JIA Website”).

Description	Date and Time
RFP Issued	June 16, 2026
Written Questions and Requests for Clarification Due	July 6, 2026 at 5:00 p.m. ET
Responses to Written Questions and Requests for Clarifications Posted	July 13, 2026 at 5:00 p.m. ET
Proposals Due (“Close Date”)	July 27, 2026 at 3:00 p.m. ET
Proposal Evaluation Completed (on or about)	One to Three Weeks after Close Date
Respondent Interviews	One to Three Weeks after Close Date
Notice of Intent to Award (emailed) (on or about)	One to Three Weeks after Close Date
Consideration and Approval of the Recommended Proposal by JIA Board of Directors	August 18, 2026
Deadline to file Protest of Award	5 calendar days after JIA Board Approval or within 10 calendar days after the Protester knows or should have known of the occurrence of the action under Protest, whichever is earlier

2.2 Respondent Questions and Inquiries. Following the posting of this RFP, Respondents may submit written questions and requests for clarification on a rolling basis via email to **Yank Moore at ymoore@jekyllisland.com**. JIA will respond in writing to written questions and post the responses on the JIA Website. If answers to submitted questions materially change the conditions and specifications of this RFP, JIA will send notice via email to Respondents who have requested notice via email and post an amendment or update to the RFP on the JIA Website. JIA personnel will not respond to questions except in writing, and no oral statement regarding this RFP will be binding on JIA. Respondents must include their company names and contact information when submitting questions and requests for clarification. Respondents may not contact JIA personnel (including members of the JIA Board of Directors) regarding this RFP other than as expressly provided in this RFP. Failure to abide by these restrictions and procedures may result in the disqualification of the offending Respondent.

2.3 Pre-Proposal Inspections. Respondents may have the opportunity to conduct inspections of the Property (each, an “Inspection”) prior to submitting a proposal for the Project by contacting **Yank Moore at ymoore@jekyllisland.com** to schedule an appointment. Recent photography of the Property is available in an attached Exhibit.

- 2.4 Negotiations.** JIA may negotiate, verbally or in writing, with the Respondent(s) whose proposal(s) is/are determined to be most advantageous to JIA. Such Respondent(s) may be asked to submit a revised written proposal. However, JIA reserves the right to accept a proposal as submitted; accordingly, it is imperative that all Respondents present their best proposals in their initial submittals.
- 2.5 JIA’s Right to Request Additional Information.** Prior to award, JIA must be assured that the selected Respondent is reasonably likely to successfully perform the obligations outlined in its proposal and those contained in the Contract. This assurance may include, but is not limited to, evidence of sufficient personnel with required skills, expertise, and experience to perform; sufficient capital, financial resources, and creditworthiness to perform; and prior experience and success in similar endeavors. In addition to any information submitted by a Respondent as part of a proposal, JIA may require the Respondent to submit additional information that JIA deems reasonably necessary to provide the above assurance of the Respondent’s reasonable likelihood of performance. Respondents will respond promptly to any such request for additional information within the time stated by JIA for such response.
- 2.6 Notice of Intent to Award.** After determining the proposal, if any, most advantageous to JIA (the “Recommended Proposal”), JIA personnel will give Notice of Intent to Award to the successful Respondent. The Notice of Intent to Award does not constitute a binding agreement; instead, it serves as notice to the successful Respondent that JIA intends to submit the Recommended Proposal to the Board for consideration and approval of the award.
- 2.7 Approval by JIA Board of Directors.** Following the Notice of Intent to Award, JIA personnel will present the Recommended Proposal and its evaluation to the Board for consideration and approval at a Board meeting. The Board’s approval, if any, will be given to that Respondent whose proposal will be most advantageous to JIA as determined by the Board in its sole discretion. The Board’s approval of the Recommended Proposal does not constitute a binding agreement. In the event the Board does not approve the Recommended Proposal, JIA may request the successful Respondent revise or amend its proposal to address any deficiencies or other elements noted by the Board.

Section 3

Proposal Evaluation and Award Factors

- 3.1** JIA will evaluate only timely submitted proposals responsive to the terms of this RFP. JIA will determine the proposal that offers the best value to JIA, based on the general factors outlined in this RFP. In evaluating proposals, JIA may utilize a review team that may include one or more JIA employees and outside individuals, including contractors, design professionals, historic preservationists, and other people.
- 3.2** On the Close Date, JIA will open timely submitted proposals and determine whether proposals are responsive to the RFP; proposals determined to be non-responsive will be eliminated from further consideration.
- 3.3** JIA will evaluate the Respondent's qualifications, expertise, and experience. Respondent, and any principal or key employee of Respondent, and any principal or key employee of any contractor, subcontractor or similar person necessary for Respondent's performance of the proposal, consents to and will authorize JIA to contact any person or organization, including conducting a criminal and financial background check, in order to make inquiries into the fitness, character, expertise, financial stability or other qualifications of such person regarding his, her or its ability to perform.
- 3.4** JIA may interview select Respondents and may request additional information to further evaluate proposals.
- 3.5** JIA will evaluate responsive proposals for substantive content. The following are general factors JIA may consider:
- (a) Quality and completeness of the proposal package;
 - (b) Qualifications, experience, and track record of Respondent and Respondent's project team, including any past work with JIA and other governmental entities;
 - (c) Demonstrated financial resources, creditworthiness, and capacity to perform;
 - (d) Cost of the Project, to include any anticipated costs to JIA;
 - (e) Anticipated compatibility with JIA and third-party business operations on Jekyll Island;
 - (f) Demonstrated understanding of Jekyll Island, the importance of the Project to the overall success of Jekyll Island, and the suitability of the Project as it relates to the larger goals and mission of the JIA;
 - (g) Quality and responsiveness of the Respondent's interview presentation and responses to interviewers' questions;
 - (h) Viability of Respondent's proposed timeline for Project deliverables, including implementation and operation, and Respondent's commitment and capability to work expeditiously and collaboratively with the JIA to implement the project.
 - (i) Overall best fit for Jekyll Island based on all factors.
- 3.6** Where JIA determines that no proposal, if accepted, would be in the best interest of JIA, JIA may cancel the RFP.

Section 4

Instructions to Respondents for Submitting Proposals

4.1 Proposal Contents. Each proposal must contain at least the following information:

- (a) Cover Letter. The cover letter should summarize the Respondent's company and key elements of the Respondent's proposal.
- (b) General Background and Relevant Experience.
 - (1) Respondent's Background. Describe the background, history, and core competencies of Respondent's company, principals, and key employees of Respondent's business and development team(s) and any contractor, subcontractor, or similar person(s) necessary for Respondent's performance of the proposal. Include resumes or CVs where appropriate.
 - (2) Relevant Experience and Projects. Describe in detail prior projects or work history relevant to this RFP, including any work performed for JIA or concerning Jekyll Island within the last ten years.
- (c) Statement of Project Understanding. Briefly describe the concept and scope of the Project proposal and the benefits to Jekyll Island.
- (d) Detailed Proposal. Include the cost and other sufficient details to allow JIA to evaluate the merits and feasibility of the proposal, the viability of the proposal, and its suitability for implementation as contemplated herein.
- (e) Project Schedule. Include a detailed estimated timeline for the Project from award of the RFP through Project completion. While not required, a Gantt Chart outlining key tasks and estimated durations is suggested. Also include a statement of any anticipated requirements or contingencies likely to affect the estimated Project timeline.
- (f) Any other information Respondent deems pertinent for consideration.

4.2 Preparing the Proposal. Respondent should carefully review all provisions and attachments of this RFP prior to submitting its proposal. All proposals must be:

- (a) Typewritten on standard letter-sized paper (e.g., 8-1/2" x 11"), except for schematics, elevations, exhibits, photographs, and other graphical submittals, which may be submitted in standard dimensions based on the document type.
- (b) Signed by Respondent's authorized representative as to any documents requiring signature.
- (c) Initialed and dated by Respondent's authorized signatory as to any corrections, erasures, or addenda.
- (d) Complete and containing all required information described in this RFP.

4.3 Submitting the Proposal.

- (a) Proposals may be submitted via mail or hand delivery to
Jekyll Island Authority
ATTN: Yank Moore, Director of Conservation
100 James Road
Jekyll Island, Georgia 31527

- (b) Proposals must be submitted in sealed opaque envelopes, plainly marked with the following:
RFP # 387
[Name of Respondent]
[Respondent's Point of Contact Preferred Email Address and Phone Number]
- (c) Proposal envelopes must contain five (5) hard copies and one (1) electronic copy (in PDF format on removable media) of the complete proposal with all supporting exhibits and documents.
- (d) Proposals must be received by JIA on or before the Close Date. Proposals not received by the Close Date will not be opened or considered.

Section 5

Protest

5.1 Right of Protest; Burden of Proof. Any Respondent who submitted a proposal and is aggrieved or adversely affected by a decision of JIA regarding the award of this RFP (the “Protester”) may file a protest of that award (the “Protest”) in accordance with this Section 5 challenging a violation of applicable law or a material deviation in the proposal award procedures (but excluding the evaluation and scoring of a proposal). No Protest shall lie with regard to an award unless the Protester shows, by a preponderance of the evidence, that:

- (a) The proposal award process violated applicable law; OR,
- (b) There was a material deviation from the process required by the RFP; AND,
- (c) The material deviation provided the putative successful Respondent with a competitive advantage not possessed by Protester; AND,
- (d) But for the deviation, Protester’s proposal would have been the Recommended Proposal.

5.2 Time for Filing Protest. Protests must be filed within the time period stated in Section 2.1, Tentative Schedule of Events. A Protest is considered filed when received by the Executive Director at the offices of JIA. Incomplete or untimely filed Protests will not be valid or considered.

5.3 Form of Protest.

- (a) Protests must be in writing and filed in duplicate.
- (b) Protests must be signed by the authorized representative of the Protester and must include at minimum the following:
 - (1) The name and address of the Protester;
 - (2) A statement with particular facts and grounds identifying the basis for the Protest, including citation to any applicable laws;
 - (3) Supporting exhibits, evidence or documents to substantiate the Protest unless not available within the filing time; in which case the expected availability date shall be indicated. If a future expected availability date is given, the Protester must supplement the Protest when the additional materials become available and must indicate on the materials submitted that they are “supplemental” and indicate whether the submission of the materials constitutes the final submission of materials for the Protest (unless requested to submit additional materials by the Executive Director). Provided, however, that the Executive Director shall not be prohibited from making a decision on a Protest prior to receipt of final Protest materials from the Protester; and
 - (4) The form of relief requested.

5.4 Delivery of Protest. Protests must be mailed or hand delivered to the following address and marked as follows:

PROTEST - RFP # 387
Attn: Executive Director
Jekyll Island Authority
100 James Road
Jekyll Island, Georgia 31527

5.5 Stay of Award During Protest. When a valid Protest has been timely filed, JIA will cease further action on the RFP until a final decision on the Protest has been issued by the Executive Director. Provided, however, where JIA determines in writing that an award without delay is necessary under the circumstances to protect the its interests, JIA may proceed with the award during the pendency of and subject to the Protest.

5.6 Information on Protests. JIA will, upon receipt of written request, make available to any interested party information submitted that bears on the substance of the Protest except where such information is permitted or required to be withheld by applicable law. JIA may, at its discretion and without obligation, provide the putative successful Respondent an opportunity to review and respond to the Protest.

5.7 Decision on Protest.

- (a) The Executive Director or his designee will review all timely filed Protests meeting the submittal requirements of this Section 5. Where the Executive Director determines the Protester has met its burden of proof, the Executive Director will issue a written decision on the Protest within thirty (30) days after receipt of the Protest. The Executive Director will determine the appropriate remedy or remedies for a successful Protest, subject to Section 5.8. Remedies may be cumulative and include, but are not limited to, the following:
- (1) Modification of the solicitation document and extension of the solicitation period;
 - (2) Cancellation of the solicitation;
 - (3) Cancellation of the selection or the award of contract; or
 - (4) Any other action allowed by applicable law.

5.8 Appeal to the Board.

- (a) The Protester may within ten (10) days after receipt of the decision by the Executive Director, submit an appeal to the Board; provided, however, no appeal will lie for a Protest not timely filed.
- (b) The appeal must contain a short and plain statement of the basis for the appeal and the relief requested, together with a copy of the original Protest and a copy of the decision of the Executive Director.
- (c) The appeal must be mailed or hand delivered to the following address and marked as follows:
- PROTEST APPEAL - RFP # 387
Chairman, Board of Directors
Jekyll Island Authority
100 James Road
Jekyll Island, Georgia 31527
- (d) Protester may request a hearing before the Board, but it shall be within the discretion of the Board to grant a hearing. If granted, the Board may establish a reasonable procedure for the conduct of such hearing not in conflict with applicable law, including, by conducting the hearing by telephonic or video means and setting reasonable time limits for presentation and argument.

- (e) The Board will have thirty (30) days after an appeal is filed or a hearing is held, whichever is later, to consider and decide the appeal. This period may be extended for good cause for a reasonable time not to exceed thirty (30) days, barring extraordinary circumstances justifying a longer extension, including, but not limited to, such events as hurricanes.
- (f) The Board's decision shall be in writing and shall be sent to the Protester.
- (g) The decision of the Board shall be final, and no further appeal will be allowed.

5.9 Protest and Appeal Costs and Expenses. Protester will be solely responsible for all Protester's costs and expenses arising from or relating to a Protest and any appeal. In no event will JIA be liable to any person for any costs or expenses arising from or relating to a Protest of this RFP or any appeal.

5.10 Exclusive Remedy. The procedures stated in this Section 5 constitute the exclusive method for asserting a claim against JIA arising out of or relating to an award under this RFP.

Section 6

General Terms and Conditions

Respondent's submittal of a proposal and any supplemental or revised proposal is subject to the following General Terms and Conditions:

- 6.1 Participation at Respondent's Risk.** Respondent participates in this RFP at Respondent's own risk and expense. Respondent will be solely responsible for all costs and expenses incurred by Respondent, or by any person acting for or on behalf of Respondent, arising from or relating to this RFP, the submittal of Respondent's proposal, and the execution of any other agreement relating to this RFP.
- 6.2 JIA Reserved Rights Concerning this RFP and Proposals.**
- (a) JIA reserves the right to waive any irregularities or technicalities in proposals where such rejection or waiver is in the best interest of JIA. JIA reserves the right to reject any proposal that is: not materially complete; not responsive; not based on sound methodologies, business principles or realistic financial or budgetary assumptions; submitted by a Respondent who has previously failed to perform properly or complete on time any project or agreement with JIA; not compatible with the character of Jekyll Island generally or, specifically, the project which is the subject of this RFP; or contrary to applicable laws. JIA reserves the right to accept an offer or proposal other than the best offer monetarily.
 - (b) JIA reserves the right to amend this RFP prior to the Close Date. JIA will give notice of any such amendment via email to any Respondent who has requested notice via email and post the same to the JIA Website. Each Respondent is individually responsible for reviewing any amendment and any other posted documents relating to this RFP. Respondents are encouraged to check the JIA Website periodically prior to submitting a proposal. Notwithstanding any provision of this RFP to the contrary, JIA reserves the right to reject all proposals and cancel the RFP at any time in its sole discretion.
 - (c) JIA reserves the right to negotiate changes in the successful Proposal after the award. These negotiations may encompass the proposed concept plan for the Project, contractual terms and conditions, and items identified during the RFP selection and negotiation processes. Based on these negotiations, JIA may decline to enter into any Contract if it is unable to negotiate final terms acceptable to JIA. In this event, JIA may declare an impasse and terminate negotiations with the successful Respondent and begin discussions with the Respondent who was ranked as the next most qualified in the evaluation process.
- 6.3 Errors or Omissions.** Any obvious errors or omissions in any specifications shall not inure to the benefit of the Respondent but shall put the Respondent on notice to inquire of or identify the same to the JIA. Respondents should make every effort to ensure proposals are complete and correct. Respondents are expected to fully inform themselves as to the conditions, requirements and specifications of the Property and the Project before submitting proposals.
- 6.4 Compliance with Laws.**
- (a) Generally. Respondents should ensure the proposal and Project will comply with all applicable laws and that Respondent and any contractor or subcontractor will obtain and maintain all approvals, certificates, licenses, permits, liability insurance, workman's compensation insurance required by applicable laws and necessary for performance of the Project prior to execution of the contract and at all times thereafter.

- (b) Equal Employment Opportunity. Respondent must abide by all applicable laws regarding nondiscrimination and equal employment opportunity practices.
- (c) ADA Guidelines. Respondents should contact JIA at least one day in advance if they require special accessibility arrangements relating to this RFP. The Georgia Relay Center at 1-800-255-0056 (TDD Only) or 1-800-255-0135 (Voice) will relay messages, in strict confidence, for the speech- and hearing-impaired. Respondents should be familiar with all Americans with Disabilities Act requirements pertaining to design standards, including those applicable to historic buildings.
- (d) Immigration and Work Authorization Compliance. Respondents must be prepared to comply with all applicable laws pertaining to the lawful presence and work authorization for employees, contractors, and subcontractors. The successful Respondent will be required to register for and implement E-Verify prior to commencement of any work.

6.5 Liability Provisions. Where Respondent enters or goes onto JIA property in order to inspect the Property or prepare the proposal, Respondent does so at its own risk and expense. By submitting a Proposal, Respondents hereby agree to indemnify, defend and hold harmless JIA, the State of Georgia and its departments, agencies and instrumentalities and all of their respective officers, members, employees and directors (hereinafter collectively referred to as the “Indemnitees”) from and against any and all claims, demands, liabilities, losses, costs or expenses, including attorneys’ fees, due to liability to a third party or parties, for any loss due to bodily injury (including death), personal injury, or property damage, including but not limited to intellectual property claims, arising directly or indirectly from the submission of a proposal, including any Inspections, by the Respondent or its agents, employees, associates, subcontractors or others working for or on behalf of Respondent.

6.6 Cone of Silence. Lobbying of JIA personnel, including Board members, regarding this RFP, or contract by any employee, member or agent of Respondent is strictly prohibited. Respondents must only contact the JIA point of contact as provided in this RFP.

6.7 Confidentiality and Georgia Open Records Act.

- (a) Public Records. Proposals submitted to JIA become public records subject to public inspection in accordance with applicable laws, including the Georgia Open Records Act, Official Code of Georgia Annotated, Section 50-18-70, et. seq., unless those records are otherwise exempt from disclosure. JIA shall have no liability under any theory in the event proposals are obtained by parties other than JIA.
- (b) Trade Secrets. In the event Respondent submits information Respondent believes constitutes trade secrets pursuant to Article 27 of Chapter 1 of Title 10 of the Official Code of Georgia, Respondent must follow the procedure set forth in O.C.G.A. § 50-18-72(a)(34) to designate that information as confidential. JIA will strictly construe any exemptions from disclosure in accordance with Georgia law.

6.8 Insurance Provisions.

- (a) JIA is under no obligation to insure Respondent’s possessions, personnel or property.
- (b) Respondent must obtain and maintain insurance coverages for general commercial liability, workers’ compensation, and employer’s liability, and any other coverages that may apply to Respondent’s Inspections or other entry on JIA property for the purpose of this RFP. The successful Respondent will be required to obtain and maintain policies of

insurance applicable to the Property and the Project prior to execution of the contract on terms acceptable to JIA.

- (c) All policies must be issued by an insurance company licensed to do business in the State of Georgia, with a minimum AM Best rating of A-, and signed by an authorized agent.
- (d) Respondent must provide certificates of insurance evidencing the coverages stated above upon request and prior to entry onto JIA property for Inspections.

Exhibit “A”
Project Concept

1. **Concept.** This Request for Proposal is an invitation by the Jekyll Island State Park Authority to qualified and experienced contractors for the construction of Four (4) pedestrian and bike bridges (the, “Project”) located in and along two ponds within Jekyll Island’s new wildlife conservation corridor (the “Property”).
2. **General Requirement for Structures.** Details for the construction of the four bridges are contained below:
 - a. **Bridge 1**
 - i. Sixty foot (60’) ADA compliant arched bridge with forty-inch (40”) sides and aluminum handrails.
 - ii. There is currently a bridge in this location, therefore, Proposals should include costs for demolition of the existing bridge and disposal of remains.
 - b. **Bridge 2**
 - i. Forty foot (40’) flat bridge with Wear Deck decking material and sides with coated wire mesh panels.
 - c. **Bridge 3**
 - i. Twenty-five foot (25’) flat bridge with Wear Deck decking material and sides with coated wire mesh panels.
 - d. **Bridge 4**
 - i. Thirty foot (30’) flat bridge with Wear Deck decking material and sides with coated wire mesh panels.

JIA engaged Land Design Associates to prepare construction plans which are attached hereto. Each of the structures referenced above should follow the design as shown on the attached construction plans.
3. **Material Specifications.** At a minimum, a Respondent’s Proposal should take into consideration the following material requirements:
 - a. JIA will provide all Wear Deck materials and screws for installing decking and angled top plate.
 - i. Corning Wear Deck 1”x6”x16’ - Gray
 - ii. Simpson DCU 10x2-3/4 316SS Screws
 - b. JIA will provide all coated wire mesh panels for the bridge sides
 - i. 48” x 96”, 2”x2” openings, 0.105” thick
 - c. Use all Salt Treated Lumber (Kiln Dried .65 ACQ)
 - d. Use all Stainless-Steel Fasteners/Hardware
4. **Timeline.** The Project must be completed and final billed by January 31, 2027.

5. **Coordination with RFP No. 386.** Simultaneously with the issuance of this RFP, JIA is issuing RFP No. 386 for the construction of pedestrian bridges on the wildlife corridor. If a Respondent wishes to respond to both RFP No. 386 and RFP No. 387, the Respondent may do so by submitting one response rather than two. However, details, such as pricing and timelines, should be provided separately so JIA may effectively compare a dual response with those that only respond to one RFP or the other.

Exhibit "B"

Map of Wildlife Conservation Corridor

The renderings attached here to show the Property and the approximate locations of the four bridge crossings.

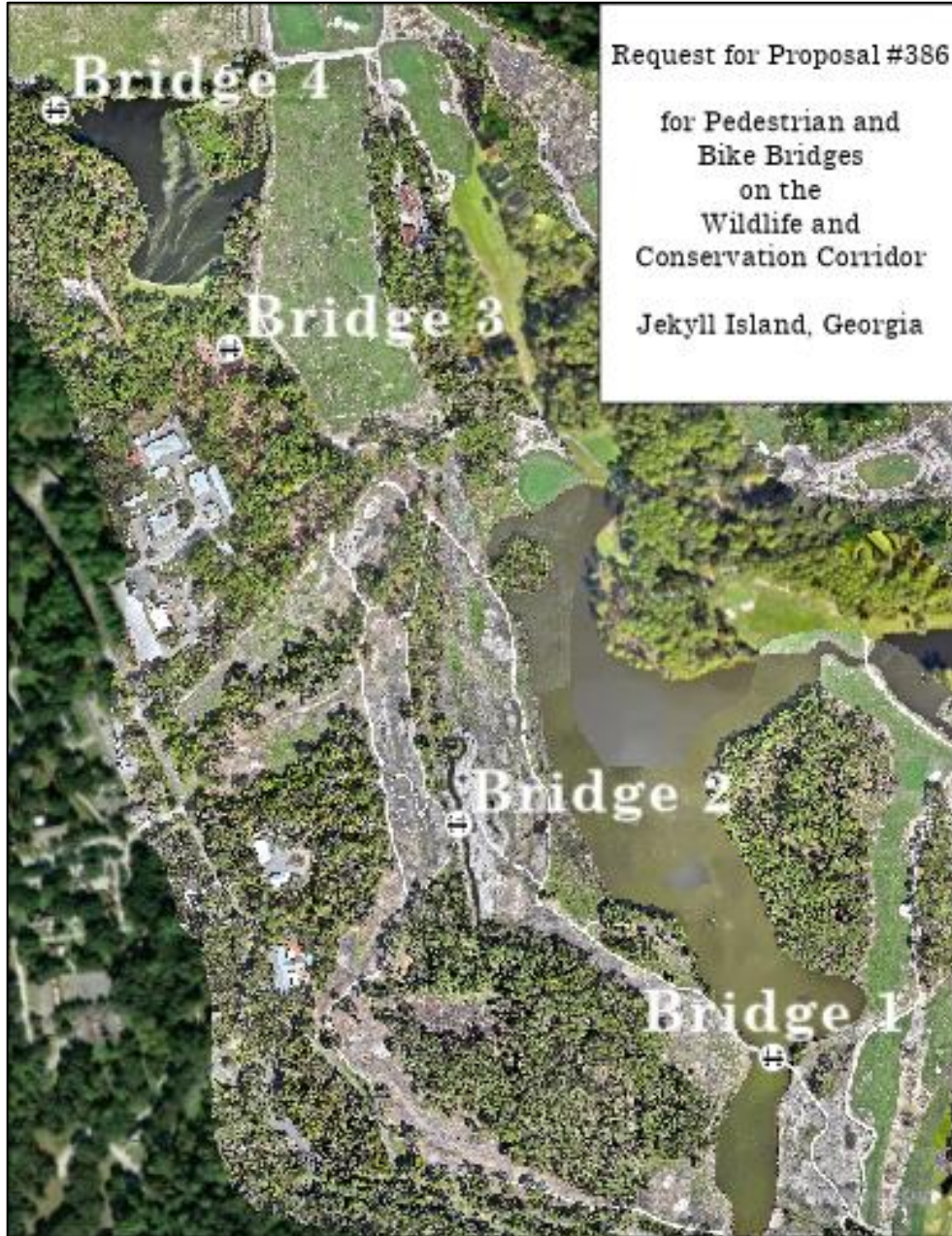

Exhibit "C"

Bridge Profile Concepts for Bridge 1

"Engineer Stamped Plans to be provided at a later date"

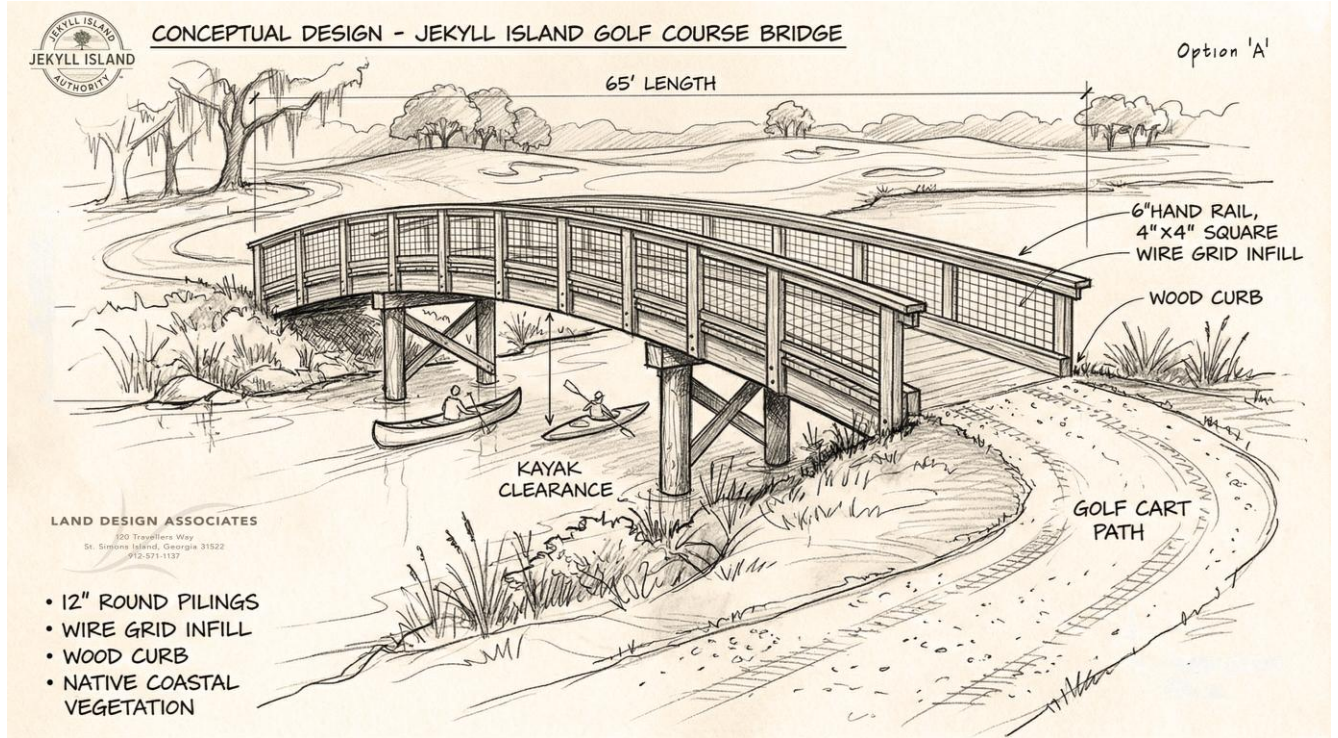

Exhibit "D"

Bridge Profile Concepts for Bridges 2, 3, and 4

"These are conceptual to aid in the bidding process"

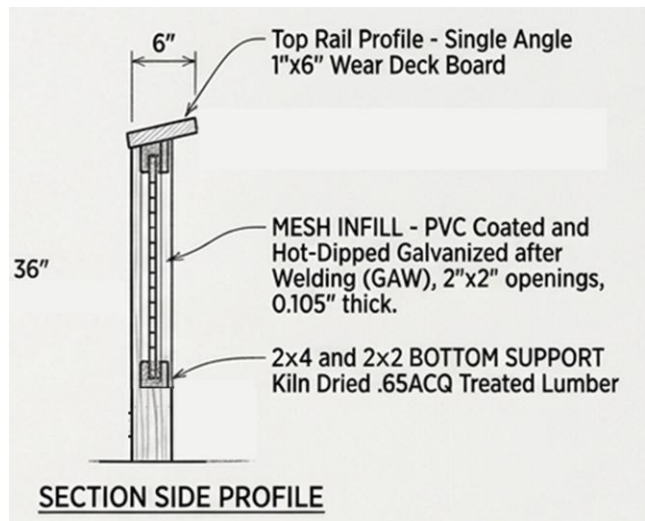
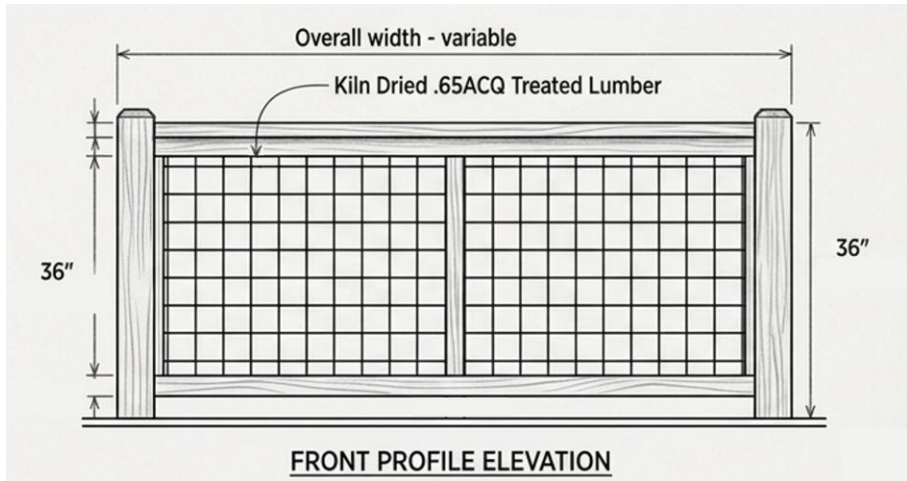
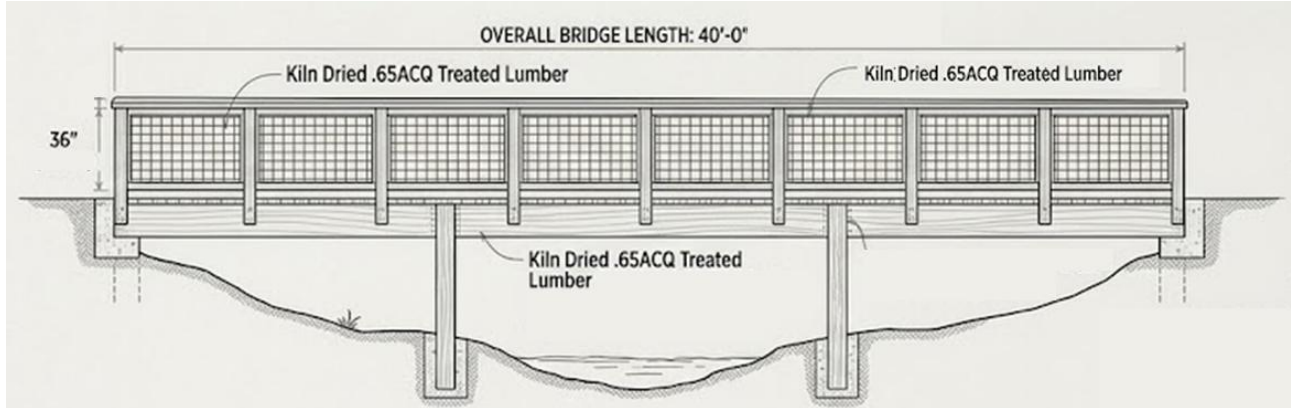

Exhibit “E”

Photos of Bridge Locations

Existing Bridge and Location for Bridge 1



Location for Bridge 2



Location for Bridge 3



Location for Bridge 4





Bridge 4

Bridge 3

Bridge 2

Bridge 1

Request for Proposal #387

for Pedestrian and
Bike Bridges
on the
Wildlife and
Conservation Corridor
Jekyll Island, Georgia